

## TD1 : ELEMENTS DE CORRIGE

### 1 ETUDE DES LIAISONS

#### Liaisons entre solides

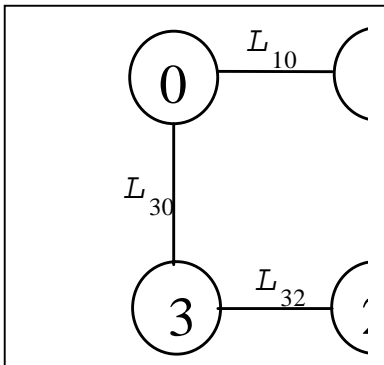

- $L_{10}$  : Pivot d'axe  $(A, \vec{x}_0)$
- $L_{32}$  : Rotule de centre C
- $L_{30}$  : Plane de normale  $(D, \vec{x}_3)$
- $L_{21}$  : Pivot glissant d'axe  $(B, \vec{x}_0)$

nb de solides  $n = 3$   
 nb de liaisons  $l = 4$   
 nb de cycles indépendants  $\gamma = 1$

#### 1.1 Etude géométrique

##### 1.1.1 FERMETURE VECTORIELLE

$$\begin{cases} AB + BC + CD + DE + EA = \vec{0} \\ R\vec{y}_1 - \lambda\vec{x}_0 - h\vec{x}_3 - v\vec{y}_0 - w\vec{z}_3 + d\vec{x}_0 = \vec{0} \end{cases} \quad (1)$$

##### 1.1.2 RESOLUTION

Projection de (1) sur  $R(A, \vec{x}_0, \vec{y}_0, \vec{z}_0)$

$$\begin{cases} -\lambda - h \cos \alpha + w \sin \alpha + d = 0 \\ R \cos \theta_{01} - v = 0 \\ R \sin \theta_{01} + h \sin \alpha - w \cos \alpha = 0 \end{cases}$$

##### 1.1.3 BILAN

paramètres géométriques:  $\lambda ; h ; v ; w ; d ; \alpha ; \theta_{01}$   $N=7$

rang géométrique:  $r=3$

paramètres géométriques donnés:  $h ; d ; \alpha ; \theta_{01}$

paramètres géométriques inconnus :  $w ; v ; \lambda$

Finalement, il vient (si  $\cos\alpha \neq 0$ )

$$\begin{aligned} w &= \frac{R \sin \theta_{01}}{\cos \alpha} + h \operatorname{tg} \alpha \\ v &= R \cos \theta_{01} \\ \lambda &= d - h \cos \alpha + h \frac{\sin^2 \alpha}{\cos \alpha} + R \sin \theta_{01} \operatorname{tg} \alpha \end{aligned}$$

#### 1.1.4 SIGNIFICATION GEOMETRIQUE

Remarque : La vitesse instantanée du point C lié au piston 2 en mouvement par rapport au barillet 1 s'écrit :

$$\vec{V}(C,2/1) = \left( \frac{dBC}{dt} \right)_{R_1} = \left( \frac{d(-\lambda \vec{x}_1)}{dt} \right)_{R_1}$$

$$\vec{V}(C,2/1) = -\frac{d\lambda}{dt} = -R\omega_{10} \operatorname{tg} \alpha \cos \theta_{01}$$

## 2 ETUDE CINEMATIQUE

$$\{v(S_1/S_0)\}_C + \{v(S_2/S_1)\}_C + \{v(S_3/S_2)\}_C - \{v(S_3/S_0)\}_C = \{0\}$$

$$\left\{ \begin{aligned} \vec{\Omega}(S_1/S_0) + \vec{\Omega}(S_2/S_1) + \vec{\Omega}(S_3/S_2) - \vec{\Omega}(S_3/S_0) &= \vec{0} \end{aligned} \right. \quad (3)$$

$$\left\{ \begin{aligned} \vec{V}(C,S_1/S_0) + \vec{V}(C,S_2/S_1) + \vec{V}(C,S_3/S_2) - \vec{V}(C,S_3/S_0) &= \vec{0} \end{aligned} \right. \quad (4)$$

Calcul de  $\vec{V}(C,S_1/S_0) = \vec{V}(A,S_1/S_0) + CA \wedge \vec{\Omega}(S_1/S_0)$

donc  $\vec{V}(C,S_1/S_0) = [\lambda \vec{x}_1 - R \vec{y}_1] \wedge \alpha_{10} \vec{x}_1 = R \alpha_{10} \vec{z}_1$

\*Projections de (3) et (4) sur  $R_0$

$$(1) \quad \alpha_{10} + \alpha_{21} + \alpha_{32} - \alpha_{30} \cos \alpha = 0$$

$$(2) \quad \beta_{32} = 0$$

$$(3) \quad \gamma_{32} + \alpha_{30} \sin \alpha = 0$$

$$(4) \quad u_{21} + w_{30} \sin \alpha = 0$$

$$(5) \quad R \alpha_{10} \sin \theta_{01} + v_{30} = 0$$

$$(6) \quad R \alpha_{10} \cos \theta_{01} - w_{30} \cos \alpha = 0$$

\*Bilan

Inconnues cinématiques:  $\alpha_{32}; \beta_{32}; \gamma_{32}; u_{21}; v_{30}; w_{30}; \alpha_{10}; \alpha_{21}; \alpha_{30}$   $N_c = 9$   
 Rang cinématique:  $r_c = 6$   
 Mobilité du mécanisme  $m = N_c - r_c = 3$  ( $m_u=1; m_i=2$ )  
 Paramètres cinématiques donnés:  $\alpha_{10}; \alpha_{21}; \alpha_{30}$   
 Paramètres cinématiques inconnus:  $\alpha_{32}; \beta_{32}; \gamma_{32}; u_{21}; v_{30}; w_{30}$

\*Système linéaire associé

$$\underbrace{\begin{bmatrix} 1 & 0 & 0 & 0 & 0 & 0 \\ 0 & 1 & 0 & 0 & 0 & 0 \\ 0 & 0 & 1 & 0 & 0 & 0 \\ 0 & 0 & 0 & 1 & 0 & \sin \alpha \\ 0 & 0 & 0 & 0 & -1 & 0 \\ 0 & 0 & 0 & 0 & 0 & \cos \alpha \end{bmatrix}}_{(A)} \underbrace{\begin{bmatrix} \alpha_{32} \\ \beta_{32} \\ \gamma_{32} \\ u_{21} \\ v_{30} \\ w_{30} \end{bmatrix}}_{(X)} = \underbrace{\begin{bmatrix} -\alpha_{10} - \alpha_{21} + \alpha_{30} \cos \alpha \\ 0 \\ -\alpha_{30} \sin \alpha \\ 0 \\ R\alpha_{10} \sin \theta_{01} \\ R\alpha_{10} \cos \theta_{01} \end{bmatrix}}_{(B)}$$

d'où

$\alpha_{32}$	$=$	$-\alpha_{10} - \alpha_{21} + \alpha_{30} \cos \alpha$
$\beta_{32}$	$=$	$0$
$\gamma_{32}$	$=$	$-\alpha_{30} \sin \alpha$
$u_{21}$	$=$	$-R\alpha_{10} \operatorname{tg} \alpha \cos \theta_{01}$
$v_{30}$	$=$	$-R\alpha_{10} \sin \theta_{01}$
$w_{30}$	$=$	$-R\alpha_{10} \frac{\cos \theta_{01}}{\cos \alpha}$

si  $\det A = -\cos \alpha \neq 0$

### 3 ETUDE DES INTER-EFFORTS

Formule de mobilité  $h = m + 6 - N_c$   
 soit  $h = 2 + 6 - (1 + 2 + 5) = 0$

\*Torseurs statiques associés aux liaisons

$$\{T(S_0 \rightarrow S_1)\}_A = \begin{Bmatrix} X_{01} & 0 \\ Y_{01} & M_{01} \\ Z_{01} & N_{01} \end{Bmatrix}_{R_0} \quad \{T(S_2 \rightarrow S_1)\}_C = \begin{Bmatrix} 0 & 0 \\ Y_{21} & M_{21} \\ Z_{21} & N_{21} \end{Bmatrix}_{R_0}$$

$$\{T(S_3 \rightarrow S_2)\}_C = \begin{Bmatrix} X_{32} & 0 \\ Y_{32} & 0 \\ Z_{32} & 0 \end{Bmatrix}_{R_0} \quad \{T(S_0 \rightarrow S_3)\}_C = \begin{Bmatrix} X_{03} & 0 \\ 0 & M_{03} \\ 0 & N_{03} \end{Bmatrix}_{R_4}$$

$$\{T(ext \rightarrow S_1)\}_A = \begin{Bmatrix} X_{E \rightarrow 1} & L_{E \rightarrow 1} \\ Y_{E \rightarrow 1} & M_{E \rightarrow 1} \\ Z_{E \rightarrow 1} & N_{E \rightarrow 1} \end{Bmatrix}_{R_0} \quad \{T(ext \rightarrow S_2)\}_C = \begin{Bmatrix} X_{E \rightarrow 2} & L_{E \rightarrow 2} \\ Y_{E \rightarrow 2} & 0 \\ Z_{E \rightarrow 2} & N_{E \rightarrow 2} \end{Bmatrix}_{R_0}$$

\*Application du P.F.S

\*Isolement de S<sub>1</sub>

$$\{T(S_0 \rightarrow S_1)\}_A + \{T(S_2 \rightarrow S_1)\}_A + \{T(ext \rightarrow S_1)\}_A = 0$$

$$\text{soit } \begin{cases} \vec{R}(S_0 \rightarrow S_1) + \vec{R}(S_2 \rightarrow S_1) + \vec{R}(ext \rightarrow S_1) = \vec{0} \\ \vec{M}(A, S_0 \rightarrow S_1) + \vec{M}(A, S_2 \rightarrow S_1) + \vec{M}(A, ext \rightarrow S_1) = \vec{0} \end{cases}$$

$$\boxed{\text{Calcul de } \vec{M}(A, S_2 \rightarrow S_1) = \vec{M}(C, S_2 \rightarrow S_1) + \vec{AC} \wedge \vec{R}(S_2 \rightarrow S_1)}$$

$$\vec{M}(A, S_2 \rightarrow S_1) = \begin{vmatrix} 0 & -\lambda & 0 \\ M_{21} & R \cos \theta_{01} & Y_{21} \\ N_{21} & R \sin \theta_{01} & Z_{21} \end{vmatrix}$$

$$\vec{M}(A, S_2 \rightarrow S_1) = \begin{bmatrix} RZ_{21} \cos \theta_{01} - RY_{21} \sin \theta_{01} \\ M_{21} + \lambda Z_{21} \\ N_{21} - \lambda Y_{21} \end{bmatrix}_{R_0}$$

Finalement, on obtient le système d'équations suivant:

$$\begin{array}{l}
 (1) \\
 (2) \\
 (3) \\
 (4) \\
 (5) \\
 (6)
 \end{array}
 \left\{ \begin{array}{l}
 X_{01} \\
 Y_{01} + Y_{21} \\
 Z_{01} + Z_{21} \\
 RZ_{21} \cos \theta_{01} - RY_{21} \sin \theta_{01} \\
 M_{01} + M_{21} + \lambda Z_{21} \\
 N_{01} + N_{21} - \lambda Y_{21}
 \end{array} \right.
 \begin{array}{l}
 = -X_{E \rightarrow 1} \\
 = -Y_{E \rightarrow 1} \\
 = -Z_{E \rightarrow 1} \\
 = -L_{E \rightarrow 1} \\
 = -M_{E \rightarrow 1} \\
 = -N_{E \rightarrow 1}
 \end{array}$$

\*Isolement de  $S_2$

$$-\{T(S_2 \rightarrow S_1)\}_C + \{T(S_3 \rightarrow S_2)\}_C + \{T(ext \rightarrow S_2)\}_C = 0$$

$$\text{soit } \left\{ \begin{array}{l}
 -\vec{R}(S_2 \rightarrow S_1) + \vec{R}(S_3 \rightarrow S_2) + \vec{R}(ext \rightarrow S_2) = \vec{0} \\
 -\vec{M}(C, S_2 \rightarrow S_1) + \vec{M}(C, S_3 \rightarrow S_2) + \vec{M}(C, ext \rightarrow S_2) = \vec{0}
 \end{array} \right.$$

Finalement, on obtient le système d'équations suivant :

$$\begin{array}{l}
 (7) \\
 (8) \\
 (9) \\
 (10) \\
 (11) \\
 (12)
 \end{array}
 \left\{ \begin{array}{l}
 X_{32} \\
 -Y_{21} + Y_{32} \\
 -Z_{21} + Z_{32} \\
 0 \\
 -M_{21} \\
 -N_{21}
 \end{array} \right.
 \begin{array}{l}
 = -X_{E \rightarrow 2} \\
 = -Y_{E \rightarrow 2} \\
 = -Z_{E \rightarrow 2} \\
 = 0 \\
 = -M_{E \rightarrow 2} \\
 = -N_{E \rightarrow 2}
 \end{array}$$

\*Isolement de  $S_3$

$$\{T(S_0 \rightarrow S_3)\}_C - \{T(S_3 \rightarrow S_2)\}_C = 0$$

$$\text{soit } \left\{ \begin{array}{l}
 \vec{R}(S_0 \rightarrow S_3) - \vec{R}(S_3 \rightarrow S_2) = \vec{0} \\
 \vec{M}(C, S_0 \rightarrow S_3) - \vec{M}(C, S_3 \rightarrow S_2) = \vec{0}
 \end{array} \right.$$

Finalement, on obtient le système d'équations suivant:

$$\begin{array}{l}
 (13) \\
 (14) \\
 (15) \\
 (16) \\
 (17) \\
 (18)
 \end{array}
 \left\{ \begin{array}{l}
 -X_{32} + X_{03} \cos \alpha - N_{03} \sin \alpha = 0 \\
 -Y_{32} = 0 \\
 -Z_{32} - X_{03} \sin \alpha = 0 \\
 0 = 0 \\
 M_{03} = 0 \\
 N_{03} \cos \alpha = 0
 \end{array} \right.$$

\*Bilan

Inconnues statiques d'inter-efforts	$N_s = \sum_{i=1}^{n+1} n_{si} = 15$
Mobilité du mécanisme	$m = 3$
Rang statique	$r_s = 6n - m = 15$
Degré d'hyperstaticité	$h = N_s - r_s = 0$

Résolution

$$\begin{array}{l}
 X_{01} = -X_{E \rightarrow 1} \\
 Y_{01} = -Y_{E \rightarrow 1} - Y_{E \rightarrow 2} \\
 Z_{01} = -Z_{E \rightarrow 1} - Z_{E \rightarrow 2} - X_{E \rightarrow 2} \operatorname{tg} \alpha \\
 M_{01} = -M_{E \rightarrow 1} - M_{E \rightarrow 2} - \lambda [Z_{E \rightarrow 2} + X_{E \rightarrow 2} \operatorname{tg} \alpha] \\
 N_{01} = -N_{E \rightarrow 1} - N_{E \rightarrow 2} + \lambda Y_{E \rightarrow 2}
 \end{array}$$

$X_{32} = -X_{E \rightarrow 2}$	$Y_{21} = Y_{E \rightarrow 2}$	$N_{03} = 0$
$Y_{32} = 0$	$Z_{21} = [Z_{E \rightarrow 2} + X_{E \rightarrow 2} \operatorname{tg} \alpha]$	$M_{03} = 0$
$Z_{32} = X_{E \rightarrow 2} \operatorname{tg} \alpha$	$M_{21} = M_{E \rightarrow 2}$	$X_{03} = -\frac{X_{E \rightarrow 2}}{\cos \alpha}$
	$N_{21} = N_{E \rightarrow 2}$	

Relation entrée sortie

$$-L_{E \rightarrow 1} = R[Z_{E \rightarrow 2} + X_{E \rightarrow 2} \operatorname{tg} \alpha] \cos \theta_{01} - R Y_{E \rightarrow 2} \sin \theta_{01}$$

Cas particulier:

$X_{E \rightarrow 2} = pS$	
$X_{E \rightarrow 2} = 0$	$-L_{E \rightarrow 1} = RpS \operatorname{tg} \alpha \cos \theta_{01}$
$X_{E \rightarrow 2} = 0$	